

FLUX G28A Compressed Air Motor Specifications

P/N FLU.01.004 (motor only)

P/N FLU.01.018 (w/hardware)

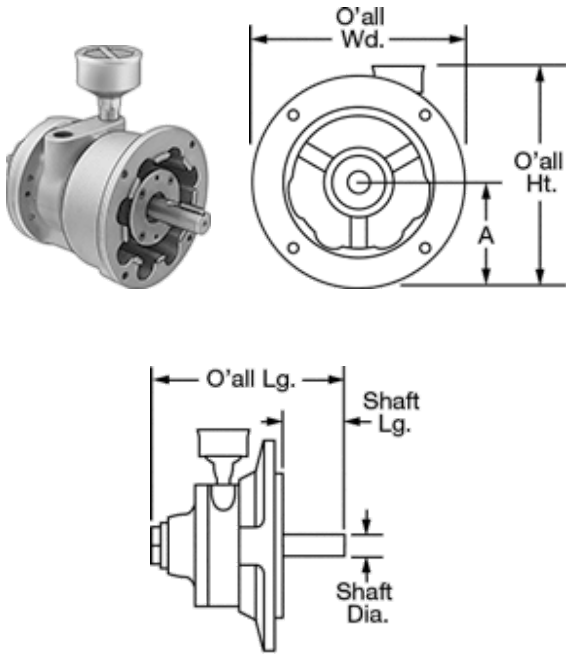

A safe alternative to electric motors for use in harsh environments, air-powered motors are spark-free and remain cool, even under continuous load. They come with a muffler to reduce noise and filter exhaust air.

@ Maximum rpm	
hp	5
Torque	132 in.-lbs.
Maximum rpm @	
Maximum psi	2,500
Maximum psi	100
Torque @ 25% Maximum rpm	
	182 in.-lbs.
Torque @ 50% Maximum rpm	
	170 in.-lbs.
hp @ 25% Maximum rpm	1.8
hp @ 50% Maximum rpm	3.2
Maximum Air Consumption	175 cfm
Noise Level	105 dB
Air Quality	Particle Free, Water Free
Overall	
Length	9 1/2"
Width	6 1/2"
Height	8 1/4"
Shaft	
Diameter	7/8"
Length	2 1/8"
Center to Base (A)	3 1/4"
Rotation	Reversible
Type	Keyed
Key Stock	Included
Motor Design	Rotary Vane
Enclosure Material	Aluminum and Iron
Mounting Orientation	Horizontal, Vertical, Inverted, Any Angle
Inlet	1/2 NPT Female
Muffler	Included
Air Lubrication	Required



