

FLUX G22A Compressed Air Motor Specifications

P/N FLU.01.002 (motor only) P/N FLU.01.002 (w/hardware)

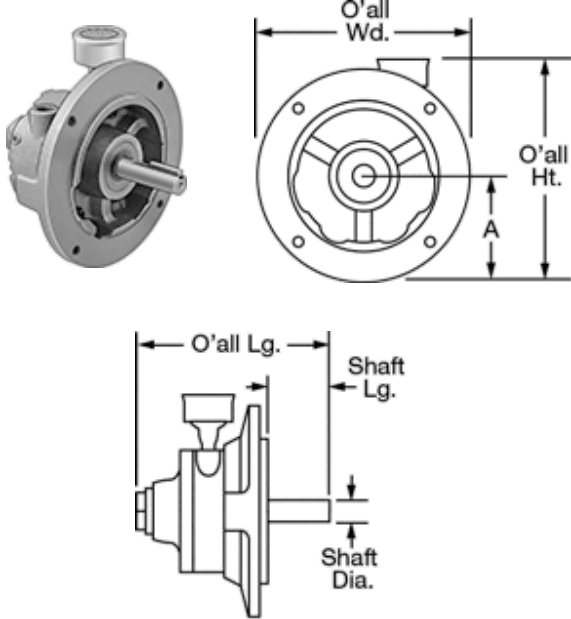

A safe alternative to electric motors for use in harsh environments, air-powered motors are spark-free and remain cool, even under continuous load. They come with a muffler to reduce noise and filter exhaust air.

@ Maximum rpm	
hp	1.7
Torque	36 in.-lbs.
Maximum rpm @ Maximum psi	3,000
Maximum psi	100
Torque @ 25% Maximum rpm	53 in.-lbs.
Torque @ 50% Maximum rpm	47 in.-lbs.
hp @ 25% Maximum rpm	0.65
hp @ 50% Maximum rpm	1.1
Maximum Air Consumption	78 cfm
Noise Level	87 dB
Air Quality	Particle Free, Water Free
Overall	
Length	6 3/4"
Width	6 1/2"
Height	7"
Shaft	
Diameter	5/8"
Length	2.06"
Center to Base (A)	3 1/4"
Rotation	Reversible
Type	Keyed
Key Stock	Included
Motor Design	Rotary Vane
Enclosure Material	Aluminum and Iron
Mounting Orientation	Horizontal, Vertical, Inverted, Any Angle
Inlet	1/4 NPT Female
Muffler	Included
Air Lubrication	Required
Related Product	Replacement Mufflers

