

## FLUX G 11A Compressed Air Motor Specifications

P/N FLU.01.005 (motor only) P/N FLU.01.017 (w/hardware)

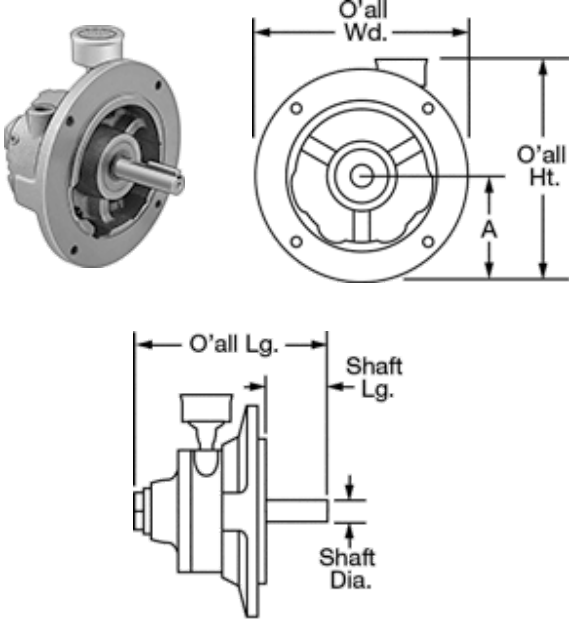

@ Maximum rpm	
hp	4
Torque	84 in.-lbs.
Maximum rpm @ Maximum psi	3,000
Maximum psi	100
Torque @ 25% Maximum rpm	110 in.-lbs.
Torque @ 50% Maximum rpm	101 in.-lbs.
hp @ 25% Maximum rpm	1.38
hp @ 50% Maximum rpm	2.5
Maximum Air Consumption	128 cfm
Noise Level	90 dB
Air Quality	Particle Free, Water Free
Overall	
Length	8 1/4"
Width	6 1/2"
Height	8"
Shaft	
Diameter	5/8"
Length	3 1/4"
Center to Base (A)	2.06"
Rotation	Reversible
Type	Keyed
Key Stock	Included
Motor Design	Rotary Vane
Enclosure Material	Aluminum and Iron
Mounting Orientation	Horizontal, Vertical, Inverted, Any Angle
Inlet	1/2 NPT Female
Muffler	Included
Air Lubrication	Required
Related Product	<a href="#">Replacement Mufflers</a>

A safe alternative to electric motors for use in harsh environments, air-powered motors are spark-free and remain cool, even under continuous load. They come with a muffler to reduce noise and filter exhaust air.

